

**OAK PARK UNIFIED SCHOOL DISTRICT
5801 E. CONIFER STREET
OAK PARK, CALIFORNIA 91377
(818) 735-3206
ADDENDUM BOARD MEETING – AGENDA #917**

DATE: Tuesday, October 20, 2015
TIME: **5:00 p.m. Closed Session**
6:00 p.m. Open Session
PLACE: Oak Park High School
Presentation Room-G9
899 Kanan Road
Oak Park, CA 91377

BOARD REPORTS/DISCUSSION/COMMUNICATION

2a Retirement Recognition for MCMS Teacher Cindy Ligeti

CONSENT

B.1.g Approve Overnight Trip for Medea Creek Middle School 8th Grade – November 9-11, 2015
Board Policy 6153 requires Board approval for student overnight trips

ACTION

B.2.h. Approve Consultant Agreement for Bond Underwriting Services
Board Policy 3312 requires Board approval for contracts for services

B.2.i. Approve Measure C6 Bond Fund Equipment Purchases – Cafeteria Upgrades at Oak Park High School and Medea Creek Middle School
Board approval required for Measure C6 purchases

B.2.j. Approve Measure C6 Bond Fund Equipment Purchases – Districtwide Security Cameras – Phase 2
Board approval required for Measure C6 purchases

Date: October 16, 2015

Anthony W. Knight, Ed.D.
Superintendent and Secretary to the
Board of Education

TO: MEMBERS, BOARD OF EDUCATION

FROM: DR. ANTHONY W. KNIGHT, SUPERINTENDENT

DATE: OCTOBER 20, 2015

SUBJECT: B.1.g. APPROVE OVERNIGHT TRIP FOR MEDEA CREEK MIDDLE SCHOOL 8th GRADE – NOVEMBER 9-11, 2015

CONSENT

ISSUE: Shall the Board of Education approve an overnight trip for Medea Creek Middle School 8th grade to Astrocamp trip?

BACKGROUND: Medea Creek has been participating in Astrocamp, in Idyllwild, for several years. Attendance is open to all 8th graders and is completely optional. Students attending will participate in classes that extend the 8th grade science curriculum (classes include Electricity and Magnetism, Telescope Viewing, Building and Launching Rockets) as well as team building activities that encourage physical challenges (Hiking, Ropes Course, Rock-Wall Climbing). Each year students say this is an outstanding educational experience.

Due to high demand, we have added a second trip to accommodate all 8th graders who expressed interest in attending. This second trip is scheduled for November 9-11, with 8:00 a.m. departure and with 4:00 p.m. return. The cost is a voluntary donation of \$335.00 (Includes transportation, classes, food and lodging), with participating chaperones paying half of the student donation. MCMS sees that all interested students (space permitting) are able to attend, regardless of cost. Chaperones include MCMS staff members and parent volunteers. The bus company is to be determined. Accept this as certification that the Principal has reviewed and verified that all the required components of the approved Field Trip Planning Guide/Checklist have been met.

ALTERNATIVES: 1. Approve the overnight trip to Astrocamp in Idyllwild.
2. Do not approve the overnight trip to Astrocamp in Idyllwild.

RECOMMENDATION: Alternative #1.

RATIONALE: It is an outstanding opportunity to study physical science, hands-on, in a unique environment, while focusing on team-building and attempting new physical challenges.

Respectfully submitted:

Anthony W. Knight, Ed.D.
Superintendent

Board Action: On motion of _____, seconded by _____, the Board of Education:

VOTE:	AYES	NOES	ABSTAIN	ABSENT
Hazelton	_____	_____	_____	_____
Helfstein	_____	_____	_____	_____
Laifman	_____	_____	_____	_____
Rosen	_____	_____	_____	_____
Ross	_____	_____	_____	_____
Student Rep.	_____	_____	_____	_____

TO: MEMBERS, BOARD OF EDUCATION
FROM: DR. ANTHONY W. KNIGHT, SUPERINTENDENT
DATE: OCTOBER 20, 2015
SUBJECT: B.2.h. APPROVE CONSULTANT AGREEMENT FOR BOND UNDERWRITING SERVICES

ACTION

ISSUE: Shall the Board approve a consultant agreement with William Blair & Company LLC for bond underwriting services?

BACKGROUND: At its meeting on September 15, 2015, the Board approved Resolution 15-17, authorizing the fourth and final issuance and sale of Measure C6 bonds. Contained within the resolution was the Board’s authorization to appoint a qualified firm to provide bond underwriting services for this issuance. Attached is an engagement letter for these services from William Blair & Company LLC, received in response to the Administrations request for proposal. Blair is well regarded for its services for small bond issuances such as the one authorized for Measure C-6, and has worked effectively and successfully with several school districts in and around Ventura County.

ALTERNATIVES:

1. Approve a consultant agreement with William Blair & Company LLC for bond underwriting services.
2. Do not approve an agreement for bond underwriting services.

RECOMMENDATION: Alternative No. 1

Prepared by: Martin Klauss, Assistant Superintendent, Business and Administrative Services

Respectfully submitted,

 Anthony W. Knight, Ed.D.
 Superintendent

Board Action: On motion of _____, seconded by _____, the Board of Education:

VOTE:	AYES	NOES	ABSTAIN	ABSENT
Hazelton	_____	_____	_____	_____
Helfstein	_____	_____	_____	_____
Laifman	_____	_____	_____	_____
Rosen	_____	_____	_____	_____
Ross	_____	_____	_____	_____
Student Rep	_____	_____	_____	_____

William Blair

October 13, 2015

Martin Klauss, Assistant Superintendent, Business and Administrative Services
Oak Park Unified School District
5801 East Conifer Street
Oak Park, CA 91377

Re: Oak Park Unified School District
Agreement to Provide Underwriting Services
Election of 2006 General Obligation Bonds, Series 2015A

Dear Mr. Klauss:

This letter (the "Agreement") constitutes an agreement by the Oak Park Unified School District (the "District") to retain William Blair & Company, L.L.C. ("*Blair*" or the "*Underwriter*") to provide investment banking services as exclusive Underwriter relating to the preparation for and public offering of the **Election of 2006 General Obligation Bonds, Series 2015A** (the "*Bonds*"), as agreed by the Underwriter and the District.

- I. The Underwriter agrees to provide underwriting services for no additional fees other than the underwriting discount on any Bonds sold including, but not limited to transactional structuring options and other analysis as needed.
- II. The Underwriter agrees to structure and to sell one or more issues of Bonds as needed or required on a mutually agreed timetable.
- III. Other terms and conditions relating to the Bonds are as follows:
 - A. The Bonds will be a general obligation of the District, payable solely from the proceeds of *ad valorem* property taxes.
 - B. Redemption terms of the Bonds by the District will be negotiated.
 - C. The Underwriter agrees to work with the District to structure the underlying documentation, which documentation will include provisions for redemption and security.
 - D. The Underwriter agrees that it will diligently attempt to bring the Bonds to market at such time as the District shall specify.
 - E. The District and the Underwriter agree that the Underwriter's Discount for assistance related to financial analysis related to the Bonds, successful marketing of the Bonds and closing of the Bond issue(s) shall not exceed the amount specified in the Authorizing Resolution of the Board of Trustees of the District, authorizing the issuance of the **Election of 2006 General Obligation Bonds, Series 2015A**. There will be no fees incurred unless Bonds are issued.

+1 310 734 5800 tel

William Blair & Company, L.L.C.
10100 Santa Monica Boulevard
Suite 300
Los Angeles, CA 90067

- F. The District agrees to pay for expenses including reasonable bond counsel and disclosure counsel fees, printing, paying agent and registrar fees, cost of rating agency fees, and other related expenses.
 - G. The Bonds will bear interest at rates determined by market conditions existing at the date of offering of the issue, subject to the approval of such interest rates and conditions by the District. The Underwriter and the District reserve the right to sell the Bonds with different maturities and upon different conditions than is presently contemplated, if it is in the mutual agreement of both parties to do so.
- IV. The Underwriter's obligation to sell the Bonds shall be subject to the satisfaction of the following conditions:
- A. A definitive Purchase Contract to be agreed upon by the Underwriter and the District.
 - B. The unqualified opinion of a nationally recognized bond counsel that the interest on the Bonds is exempt from Federal income taxation.
 - C. The unqualified opinion of counsel that the Bonds are duly issued under appropriate Federal and State securities laws and is otherwise in conformance with other laws and codes, as applicable.
 - D. Approval of the form and substance of the documents in connection with the issuance of the Bonds by the Underwriter.
 - E. In the judgment of the Underwriter, after due inquiry, there shall not have occurred any material adverse change in the affairs or financial condition of the District or its affiliates since the date of the most recent audited financial statements provided to Underwriter except as previously disclosed to the Underwriter or contained in audited or unaudited financial statements of the District.
- V. *Compliance with MSRB Rule G-17 and the SEC Municipal Advisor Rule.*

Per MSRB Rule G-17 and the SEC Municipal Advisor Rule, William Blair, in its capacity as an underwriter of municipal securities, is not recommending an action to the District as the municipal entity or obligated person. The information provided is not intended to be and should not be construed as "advice" within the meaning of Section 15B of the Securities Exchange Act of 1934. This information is being provided for discussion purposes, and the District should discuss any information and material contained in this communication with any and all internal or external advisors and experts that the District deems appropriate before acting on this information or material. Unless otherwise agreed, the Firm is not acting as a municipal advisor to the District and does not owe a fiduciary duty pursuant to Section 15B of the Exchange Act to the District with respect to the information and material contained in this communication. In our capacity as underwriter, William Blair's primary role is to purchase the securities as a principal in a commercial, arms' length transaction, and the firm will have financial and other interests that differ from the District's.

VI. *Authority.*

Each of the parties to this Agreement represents that it has duly authorized the execution, delivery and performance of this Agreement and that neither such execution and delivery nor the performance of its obligations hereunder conflict with or violate any provision of law, rule or regulation, or any instrument to which it is a party or to which any of its property is subject and that this Agreement is a valid and binding obligation.

VII. *Liability and Indemnification.*

- A. The District agrees that neither Blair nor any member, principal or employee of Blair shall be liable for any error in judgment or for any act or omission to act by Blair or any such person, except for any error in judgment, act or omission resulting from Blair's or such person's negligence, gross negligence, willful misconduct or malfeasance, in which case Blair shall indemnify and hold harmless District and each Board member and employee of District (collectively, the "District Indemnified Party") against any losses, claims, damages or liabilities, joint or several, to which any District Indemnified Party may become subject. Blair shall have no liability to the District if the issuance of the Securities does not occur for any reason, and has no obligation to purchase the Securities under any circumstances.
- B. To the extent permitted by applicable law, the District shall indemnify and hold harmless Blair and each member, principal and employee of Blair (collectively, the "Indemnified Party") against any losses, claims, damages or liabilities, joint or several, to which any Indemnified Party may become subject, insofar as such losses, claims, damages or liabilities (or actions in respect thereof) arise out of or are based upon an untrue statement of a material fact contained in any Disclosure Document, or any amendment or supplement thereto, or arise out of or are based upon the omission or alleged omission to state therein a material fact required to be stated therein or necessary to make the statements therein not misleading, and will reimburse each Indemnified Party for any legal or other expenses reasonably incurred by such Indemnified Party in connection with investigating or defending any such action or claim. The District is responsible for the truth, accuracy and completeness of all information relating to the District.
- C. The reimbursement, indemnity and contribution obligations of the parties hereunder shall be in addition to any liability which the parties may otherwise have.

VIII. *Termination and Assignment.*

- A. This Agreement may be terminated by either party at any time upon 30 days' prior written notice to the other party. Such termination shall be without the payment of any penalty and without liability of either party to the other, except (i) for any compensation and expense reimbursements due in accordance with Section III (F.) and (ii) that Blair and the District shall continue to be entitled to the benefits of Section VII following any such termination.
- B. No assignment of this Agreement by Blair shall be effective without the written consent of the District.

- IX. *Notices.* Any notice or other written communication provided for herein shall be mailed to District at its address set forth above or to William Blair & Company, LLC at 10100 Santa Monica Blvd., Suite 300, Los Angeles, California, 90067, unless either party notifies the other in writing of a different address.
- X. *General.* The validity and interpretation of this Agreement shall be governed by, and construed and enforced in accordance with, the laws of the State of California applicable to Agreements made and to be fully performed therein. This Agreement may not be modified or amended except in writing executed by the parties hereto. This Agreement may be signed in counterparts, each of which shall be deemed an original and all of which shall constitute one and the same instrument.
- XI. This Agreement is agreed to, accepted and effective as of the date set forth above.

OAK PARK UNIFIED SCHOOL DISTRICT

By: _____

Title:

WILLIAM BLAIR & COMPANY, L.L.C.

By: 

Title: Kenneth Gillespie
Director

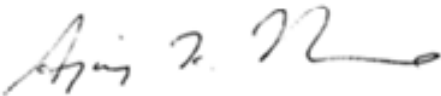

Ajay Thomas
Managing Director

TO: MEMBERS, BOARD OF EDUCATION
FROM: DR. ANTHONY W. KNIGHT, SUPERINTENDENT
DATE: OCTOBER 20, 2015
SUBJECT: B.2.i. APPROVE MEASURE C6 BOND FUND EQUIPMENT PURCHASES – CAFETERIA UPGRADES AT OAK PARK HIGH SCHOOL AND MEDEA CREEK MIDDLE SCHOOL

ACTION

ISSUE: Shall the Board approve Measure C6 bond fund equipment purchases for Cafeteria Upgrades at Oak Park High School and Medea Creek Middle School?

BACKGROUND: As approved by Oak Park voters, Bond Measure C6 specifically provides for the purchase or replacement of “Food Preparation and Kitchen Equipment – to furnish and equip ...kitchen facilities at each school site for student meal preparation...”

Consistent with the District’s Goals and Moral Imperatives, the Child Nutrition Services department is upgrading the aging cafeteria equipment at Oak Park High School and Medea Creek Middle School to return to preparation of healthy, wholesome meals, rather than pre-packaged, heat-and-serve fare. Child Nutrition Services and District staff are requesting the Board’s authorization to purchase the food services equipment itemized on the attached quotes from Action Sales, totaling \$143, 172.00, utilizing funds from the Measure C6 bond fund. Assuming the Board’s approval it is anticipated that the new equipment will be delivered and installed over winter break in December 2015.

- ALTERNATIVES:**
1. Approve the Measure C6 bond fund equipment purchases from Action Sales for cafeteria upgrades at Oak Park High School and Medea Creek Middle School, in the amount of \$143,172.00.
 2. Do not approve the equipment purchase.

RECOMMENDATION: Alternative No. 1

Prepared by: Martin Klauss, Assistant Superintendent, Business and Administrative Services

Respectfully submitted,

 Anthony W. Knight, Ed.D.
 Superintendent

Board Action: On motion of _____, seconded by _____, the Board of Education:

VOTE:	AYES	NOES	ABSTAIN	ABSENT
Hazelton	_____	_____	_____	_____
Helfstein	_____	_____	_____	_____
Laifman	_____	_____	_____	_____
Rosen	_____	_____	_____	_____
Ross	_____	_____	_____	_____
Student Rep	_____	_____	_____	_____

Quote Date 9/24/2015



ACTION SALES

www.actionsales.com

Project: MADEA CREEK, Oak Park, CA

Consultant: Sales person - Jimmy Chan
Rep: Email - Jimmy@ActionSales.com
Regional Mgr: (626)810-2277 xt. 253

QUOTATION

Item #	Qty	Product:	ESSENCE	Price Each	Total Price
--------	-----	----------	---------	------------	-------------

Prices are good if PO is received for (2) schools (Oak Park High School and Medea Creek Middle School with identical counters), with manufacturing, shipping and invoicing for the counters completed in 2015

1	1	LNL-66-Lock-N-Load Solid Top Counter, 66"L x 34"W x 34"H, with welded 1" stainless steel tubular base, stainless steel interior, 6" adjustable stainless steel legs		\$3,150	\$3,150.00
	1	14 Gauge Stainless Steel Top			
	2	Electrical receptacle with wiring to j-box			
	1	J-box with cord and plug			
	1	Laminated Front Panel			
	2	Bolting to adjacent counter			
	1	Toe kick plate, black powder coated			

ADD ALTERNATE 1 Modify item 1 with FS-V Vertical Food Shield with (2) glass end panels, if required **ADD \$1400 TOTAL** **\$1,400.00**

ADD ALTERNATE 3 Modify item 1 with extended top and angled front panel in lieu of standard, if required **ADD \$1530 TOTAL** **\$1,530.00**

3	1	ULS36 Essence Utility Counter, 36"L x 34"W x 34"H, with welded 1" stainless steel tubular base, removable 18 gauge stainless steel undershelf and 6" adjustable stainless steel legs		\$3,125	\$3,125.00
	1	Modify counter to angled corner unit			
	1	14 Gauge Stainless Steel Top			
	1	Laminated Front Panel			
	1	Laminated End Panel			
	1	Bolting to adjacent counter item #1			
	1	Tight Link			
	1	Toe kick plate, black powder coated			

4	1	HLS78 Essence Hot Food Counter, 78"L x 34"W x 34"H, with welded 1" stainless steel tubular base, removable 18 gauge stainless steel undershelf and 6" adjustable stainless steel legs		\$7,475	\$7,475.00
	1	14 Gauge Stainless Steel Top			
	1	Straight top: NO Recess			
	1	DI-EF-5D Hot Food Wells: 5 well, Energy Efficient drop in unit, drain with shut off valve, verify voltage			
	1	Modify hot wells to have no drains			

	1	FS-Food shield with convertible 2-position front glass and glass shelf. Verify black powder coat or stainless steel finish		
	2	Food shield glass end panel		
	1	J-box with cord and plug		
	1	Laminated Front Panel		
	2	Laminated End Panel		
	1	Open storage on operator side		
	1	Tight Link		
	1	Toe kick plate, black powder coated		
5	1	ULS30 Essence Utility Counter, 30"L x 34"W x 34"H, with welded 1" stainless steel tubular base, removable 18 gauge stainless steel undershelf and 6" adjustable stainless steel legs	\$3,135	\$3,135.00
	1	14 Gauge Stainless Steel Top		
	1	FS-Food shield with convertible 2-position front glass and glass shelf. Verify black powder coat or stainless steel finish		
	2	Food shield glass end panel		
	1	Laminated Front Panel		
	1	Open storage on operator side		
	1	Tight Link		
	1	Toe kick plate, black powder coated		
6	1	CLS60 Essence Cold Food Counter 60"L x 34"W x 34"H, with welded 1" stainless steel tubular base, removable 18 gauge stainless steel undershelf and 6" adjustable stainless steel legs	\$9,800	\$9,800.00
	1	14 Gauge Stainless Steel Top		
	1	DI-2050TA-Cold Wells: 4 full size pan drop in Temp-est Aire unit, NSF 7, self contained, 1/3 HP, NEMA 5-15		
	1	Condensate evaporator		
	1	FS-Food shield with convertible 2-position front glass and glass shelf. Verify black powder coat or stainless steel finish		
	2	Food shield glass end panel		
	1	Receptacle with cord and plug		
	1	Laminated Front Panel		
	1	Stainless steel hinged louvered doors on operator side at compressor with open storage at remaining length		
	1	Tight Link		
	1	Toe kick plate, black powder coated		
7	1	CS30 Essence In-line Cashier Station, 30"L x 34"W x 34"H, includes top, tray rail, cash drawer with insert tray, grommet hole and receptacle, on 6" legs	\$3,225	\$3,225.00
	1	Laminated Front Panel		
	1	Laminated End Panel		
	1	Open storage on operator side		
	1	Toe kick plate, black powder coated		
8	1	ULS36 Essence Utility Counter, 36"L x 34"W x 34"H, with welded 1" stainless steel tubular base, removable 18 gauge stainless steel undershelf and 6" adjustable stainless steel legs	\$3,125	\$3,125.00
	1	Modify counter to angled corner unit		
	1	14 Gauge Stainless Steel Top		
	1	Laminated Front Panel		
	1	Laminated End Panel		

	1	Bolting to adjacent counter item #1		
	1	Tight Link		
	1	Toe kick plate, black powder coated		
9	1	HLS78 Essence Hot Food Counter, 78"L x 34"W x 34"H, with welded 1" stainless steel tubular base, removable 18 gauge stainless steel undershelf and 6" adjustable stainless steel legs	\$7,475	\$7,475.00
	1	14 Gauge Stainless Steel Top		
	1	Straight top: NO Recess		
	1	DI-EF-5D Hot Food Wells: 5 well, Energy Efficient drop in unit, drain with shut off valve, verify voltage		
	1	Modify hot wells to have no drains		
	1	FS-Food shield with convertible 2-position front glass and glass shelf. Verify black powder coat or stainless steel finish		
	2	Food shield glass end panel		
	1	J-box with cord and plug		
	1	Laminated Front Panel		
	2	Laminated End Panel		
	1	Open storage on operator side		
	1	Tight Link		
	1	Toe kick plate, black powder coated		
10	1	ULS30 Essence Utility Counter, 30"L x 34"W x 34"H, with welded 1" stainless steel tubular base, removable 18 gauge stainless steel undershelf and 6" adjustable stainless steel legs	\$3,135	\$3,135.00
	1	14 Gauge Stainless Steel Top		
	1	FS-Food shield with convertible 2-position front glass and glass shelf. Verify black powder coat or stainless steel finish		
	2	Food shield glass end panel		
	1	Laminated Front Panel		
	1	Open storage on operator side		
	1	Tight Link		
	1	Toe kick plate, black powder coated		
11	1	CLS60 Essence Cold Food Counter 60"L x 34"W x 34"H, with welded 1" stainless steel tubular base, removable 18 gauge stainless steel undershelf and 6" adjustable stainless steel legs	\$9,800	\$9,800.00
	1	14 Gauge Stainless Steel Top		
	1	DI-2050TA-Cold Wells: 4 full size pan drop in Temp-est Aire unit, NSF 7, self contained, 1/3 HP, NEMA 5-15		
	1	Condensate evaporator		
	1	FS-Food shield with convertible 2-position front glass and glass shelf. Verify black powder coat or stainless steel finish		
	2	Food shield glass end panel		
	1	Receptacle with cord and plug		
	1	Laminated Front Panel		
	1	Stainless steel hinged louvered doors on operator side at compressor with open storage at remaining length		
	1	Tight Link		
	1	Toe kick plate, black powder coated		
12	1	CS30 Essence In-line Cashier Station, 30"L x 34"W x 34"H, includes top, tray rail, cash drawer with insert tray, grommet hole and receptacle, on 6" legs	\$3,225	\$3,225.00

- 1 Laminated Front Panel
- 1 Laminated End Panel
- 1 Open storage on operator side
- 1 Toe kick plate, black powder coated

ADD ALTERNATE 2	Modify items 4, 5, 6, 9, 10 & 11 with stainless steel hinged doors on operator side, if required ADD \$2330 TOTAL	\$2,330.00
ADD ALTERNATE 5	Modify items 4 & 9 with recess for sheet pans in lieu of straight, if required ADD \$1150 TOTAL	\$1,150.00
UPGRADE	Additional 3-year warranty on top of the standard 2-years. Total 5-year warranty.	\$3,000.00

TOTAL EQUIPMENT PRICE **\$66,080.00**

LABOR-TO UNCRATE AND SET IN PLACE **\$550.00**

TAX 7.50% **\$4,956.00**
TOTAL **\$71,586.00**

****Pricing is based on items and quantities as noted on quote. Changing of quantities will/may require re quoting the project. Please consult Action Sales for revised quote based upon new items/quantities required.**

****Prices quoted will be held for 90 days unless otherwise noted.**

****Prices quoted are F.O.B. factory.**

**** Lead times vary from 6 to 10 weeks after receipt of all approvals, field dimensions, and material selections.**



ARE YOU A COOL SCHOOL PARTICIPANT? IF SO, YOU COULD EARN 78,500 POINTS FOR THE PURCHASE OF THIS SERVING EQUIPMENT. IF YOU ARE NOT A PARTICIPANT, IT IS FREE TO JOIN. JUST VISIT WWW.COOLSCHOOL.COM TO SIGN UP OR CALL COOL SCHOOL AT 763-262-3150.

Material Notes:

**** Laminate pricing based on standard single color laminate selections. Consult factory for pricing on any special color laminates.**

General Notes:

**** Hinged doors, during shipment, may require adjustment at site. Door adjustment by others.**

**** Final mechanical connections are BY OTHERS.**

REVISED

MEDEA CREEK MIDDLE SCHOOL
OAK PARK, CA



MULTITERIA
1444 N FARNSWORTH AVE
AURORA, IL 60505

MULTITERIA RESERVES PROPRIETARY RIGHTS TO THIS DRAWING AND THE DATA FROM THIS DRAWING. THIS DRAWING AND DATA ARE CLASSIFIED AS CONFIDENTIAL AND ARE NOT TO BE USED OR REPRODUCED FOR ANY PURPOSE WITHOUT WRITTEN CONSENT OF MULTITERIA.

PROJECT NO.	2510.10.15.15E
DATE:	10/15/15
SCALE:	1/2"=1'-0"
DRAWN BY:	SMP
AUTOCAD D SIZE	

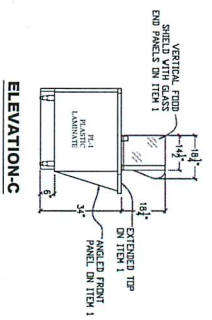
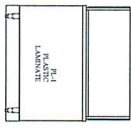
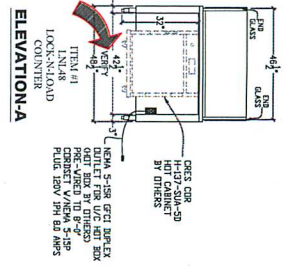
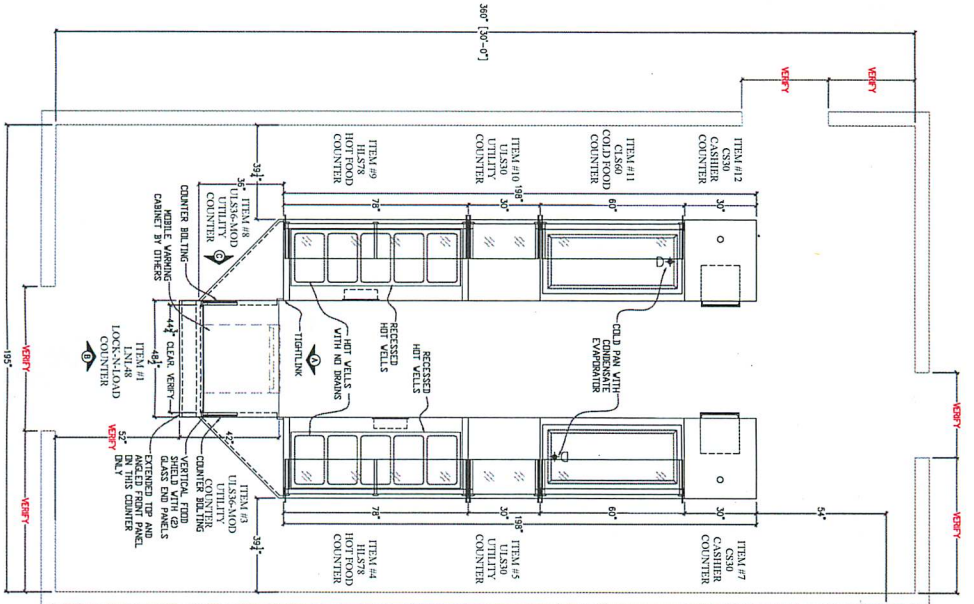

- MATERIAL/COLOR SELECTIONS TO BE VERIFIED:**
1. COUNTER TOP: 1/4" DC STAINLESS STEEL
 2. CABINETS: 1/2" DC STAINLESS STEEL
 3. MAIN SIDE PANEL: 1/2" DC STAINLESS STEEL FINISH OR STAINLESS STEEL FINISH
 4. 1/4" LAMINATE: PLASTIC LAMINATE/LAMINATE/PAPER
 5. 1/4" DC STAINLESS STEEL FINISH OR STAINLESS STEEL FINISH
- MANUFACTURING NOTES:**
1. 1" SQ. STAINLESS STEEL WELD JOINTS
 2. STAINLESS STEEL WELD JOINTS TO BE REMOVABLE LAMINATE PANELS AND JOINING CHANNELS
 3. STAINLESS STEEL WELD JOINTS TO BE REMOVABLE LAMINATE PANELS AND JOINING CHANNELS
 4. OPTIONAL STAINLESS STEEL DOORS ON OPERATOR SIDE OF HOT FOOD COUNTERS
 5. NO DRIVING IN HOT METALS
 6. ALL STAINLESS STEEL DOORS TO BE 2" MIN. CLEARANCE TO THE FACE OF THE METAL
 7. STAINLESS STEEL DOORS ON OPERATOR SIDE WITH THIN LATCHES

ITEM #	QUANTITY	MANUFACTURER	MODEL NO.	DESCRIPTION	PO NUMBER
1	1	MATCO	MATCO-1	HOT FOOD COUNTER	MULTITERIA
2	2	MATCO	MATCO-2	COLD FOOD COUNTER	MULTITERIA



Quote Date 9/24/2015



ACTION SALES

www.actionsales.com

Project: OAK PARK
HS, Oak Park,
CA

Consultant: Sales person - Jimmy Chan
Rep: Email - Jimmy@ActionSales.com
Regional Mgr: (626)810-2277 xt. 253

QUOTATION

Item #	Qty	Product:	ESSENCE	Price Each	Total Price
Prices are good if PO is received for (2) schools (Oak Park High School and Medea Creek Middle School with identical counters), with manufacturing, shipping and invoicing for the counters completed in 2015					
1	1	LNL-66-Lock-N-Load Solid Top Counter, 66"L x 34"W x 34"H, with welded 1" stainless steel tubular base, stainless steel interior, 6" adjustable stainless steel legs		\$3,150	\$3,150.00
	1	14 Gauge Stainless Steel Top			
	2	Electrical receptacle with wiring to j-box			
	1	J-box with cord and plug			
	1	Laminated Front Panel			
	2	Bolting to adjacent counter			
	1	Toe kick plate, black powder coated			
ADD ALTERNATE 1		Modify item 1 with FS-V Vertical Food Shield with (2) glass end panels, if required ADD \$1400 TOTAL			\$1,400.00
ADD ALTERNATE 3		Modify item 1 with extended top and angled front panel in lieu of standard, if required ADD \$1530 TOTAL			\$1,530.00
3	1	ULS36 Essence Utility Counter, 36"L x 34"W x 34"H, with welded 1" stainless steel tubular base, removable 18 gauge stainless steel undershelf and 6" adjustable stainless steel legs		\$3,125	\$3,125.00
	1	Modify counter to angled corner unit			
	1	14 Gauge Stainless Steel Top			
	1	Laminated Front Panel			
	1	Laminated End Panel			
	1	Bolting to adjacent counter item #1			
	1	Tight Link			
	1	Toe kick plate, black powder coated			
4	1	HLS78 Essence Hot Food Counter, 78"L x 34"W x 34"H, with welded 1" stainless steel tubular base, removable 18 gauge stainless steel undershelf and 6" adjustable stainless steel legs		\$7,475	\$7,475.00
	1	14 Gauge Stainless Steel Top			
	1	Straight top: NO Recess			
	1	DI-EF-5D Hot Food Wells: 5 well, Energy Efficient drop in unit, drain with shut off valve, verify voltage			
	1	Modify hot wells to have no drains			

	1	FS-Food shield with convertible 2-position front glass and glass shelf. Verify black powder coat or stainless steel finish		
	2	Food shield glass end panel		
	1	J-box with cord and plug		
	1	Laminated Front Panel		
	2	Laminated End Panel		
	1	Open storage on operator side		
	1	Tight Link		
	1	Toe kick plate, black powder coated		
5	1	ULS30 Essence Utility Counter, 30"L x 34"W x 34"H, with welded 1" stainless steel tubular base, removable 18 gauge stainless steel undershelf and 6" adjustable stainless steel legs	\$3,135	\$3,135.00
	1	14 Gauge Stainless Steel Top		
	1	FS-Food shield with convertible 2-position front glass and glass shelf. Verify black powder coat or stainless steel finish		
	2	Food shield glass end panel		
	1	Laminated Front Panel		
	1	Open storage on operator side		
	1	Tight Link		
	1	Toe kick plate, black powder coated		
6	1	CLS60 Essence Cold Food Counter 60"L x 34"W x 34"H, with welded 1" stainless steel tubular base, removable 18 gauge stainless steel undershelf and 6" adjustable stainless steel legs	\$9,800	\$9,800.00
	1	14 Gauge Stainless Steel Top		
	1	DI-2050TA-Cold Wells: 4 full size pan drop in Temp-est Aire unit, NSF 7, self contained, 1/3 HP, NEMA 5-15		
	1	Condensate evaporator		
	1	FS-Food shield with convertible 2-position front glass and glass shelf. Verify black powder coat or stainless steel finish		
	2	Food shield glass end panel		
	1	Receptacle with cord and plug		
	1	Laminated Front Panel		
	1	Stainless steel hinged louvered doors on operator side at compressor with open storage at remaining length		
	1	Tight Link		
	1	Toe kick plate, black powder coated		
7	1	CS30 Essence In-line Cashier Station, 30"L x 34"W x 34"H, includes top, tray rail, cash drawer with insert tray, grommet hole and receptacle, on 6" legs	\$3,225	\$3,225.00
	1	Laminated Front Panel		
	1	Laminated End Panel		
	1	Open storage on operator side		
	1	Toe kick plate, black powder coated		
8	1	ULS36 Essence Utility Counter, 36"L x 34"W x 34"H, with welded 1" stainless steel tubular base, removable 18 gauge stainless steel undershelf and 6" adjustable stainless steel legs	\$3,125	\$3,125.00
	1	Modify counter to angled corner unit		
	1	14 Gauge Stainless Steel Top		
	1	Laminated Front Panel		
	1	Laminated End Panel		

	1	Bolting to adjacent counter item #1		
	1	Tight Link		
	1	Toe kick plate, black powder coated		
9	1	HLS78 Essence Hot Food Counter, 78"L x 34"W x 34"H, with welded 1" stainless steel tubular base, removable 18 gauge stainless steel undershelf and 6" adjustable stainless steel legs	\$7,475	\$7,475.00
	1	14 Gauge Stainless Steel Top		
	1	Straight top: NO Recess		
	1	DI-EF-5D Hot Food Wells: 5 well, Energy Efficient drop in unit, drain with shut off valve, verify voltage		
	1	Modify hot wells to have no drains		
	1	FS-Food shield with convertible 2-position front glass and glass shelf. Verify black powder coat or stainless steel finish		
	2	Food shield glass end panel		
	1	J-box with cord and plug		
	1	Laminated Front Panel		
	2	Laminated End Panel		
	1	Open storage on operator side		
	1	Tight Link		
	1	Toe kick plate, black powder coated		
10	1	ULS30 Essence Utility Counter, 30"L x 34"W x 34"H, with welded 1" stainless steel tubular base, removable 18 gauge stainless steel undershelf and 6" adjustable stainless steel legs	\$3,135	\$3,135.00
	1	14 Gauge Stainless Steel Top		
	1	FS-Food shield with convertible 2-position front glass and glass shelf. Verify black powder coat or stainless steel finish		
	2	Food shield glass end panel		
	1	Laminated Front Panel		
	1	Open storage on operator side		
	1	Tight Link		
	1	Toe kick plate, black powder coated		
11	1	CLS60 Essence Cold Food Counter 60"L x 34"W x 34"H, with welded 1" stainless steel tubular base, removable 18 gauge stainless steel undershelf and 6" adjustable stainless steel legs	\$9,800	\$9,800.00
	1	14 Gauge Stainless Steel Top		
	1	DI-2050TA-Cold Wells: 4 full size pan drop in Temp-est Aire unit, NSF 7, self contained, 1/3 HP, NEMA 5-15		
	1	Condensate evaporator		
	1	FS-Food shield with convertible 2-position front glass and glass shelf. Verify black powder coat or stainless steel finish		
	2	Food shield glass end panel		
	1	Receptacle with cord and plug		
	1	Laminated Front Panel		
	1	Stainless steel hinged louvered doors on operator side at compressor with open storage at remaining length		
	1	Tight Link		
	1	Toe kick plate, black powder coated		
12	1	CS30 Essence In-line Cashier Station, 30"L x 34"W x 34"H, includes top, tray rail, cash drawer with insert tray, grommet hole and receptacle, on 6" legs	\$3,225	\$3,225.00

- 1 Laminated Front Panel
- 1 Laminated End Panel
- 1 Open storage on operator side
- 1 Toe kick plate, black powder coated

ADD ALTERNATE 2	Modify items 4, 5, 6, 9, 10 & 11 with stainless steel hinged doors on operator side, if required ADD \$2330 TOTAL	\$2,330.00
ADD ALTERNATE 5	Modify items 4 & 9 with recess for sheet pans in lieu of straight, if required ADD \$1150 TOTAL	\$1,150.00
UPGRADE	Additional 3-year warranty on top of the standard 2-years. Total 5-year warranty.	\$3,000.00

TOTAL EQUIPMENT PRICE **\$66,080.00**

LABOR-TO UNCRATE AND SET IN PLACE **\$550.00**

TAX 7.50% **\$4,956.00**
TOTAL **\$71,586.00**

****Pricing is based on items and quantities as noted on quote. Changing of quantities will/may require re quoting the project. Please consult Action Sales for revised quote based upon new items/quantities required.**

****Prices quoted will be held for 90 days unless otherwise noted.**

****Prices quoted are F.O.B. factory.**

**** Lead times vary from 6 to 10 weeks after receipt of all approvals, field dimensions, and material selections.**



ARE YOU A COOL SCHOOL PARTICIPANT? IF SO, YOU COULD EARN 78,500 POINTS FOR THE PURCHASE OF THIS SERVING EQUIPMENT. IF YOU ARE NOT A PARTICIPANT, IT IS FREE TO JOIN. JUST VISIT WWW.COOLSCHOOL.COM TO SIGN UP OR CALL COOL SCHOOL AT 763-262-3150.

Material Notes:

**** Laminate pricing based on standard single color laminate selections. Consult factory for pricing on any special color laminates.**

General Notes:

**** Hinged doors, during shipment, may require adjustment at site. Door adjustment by others.**

**** Final mechanical connections are BY OTHERS.**

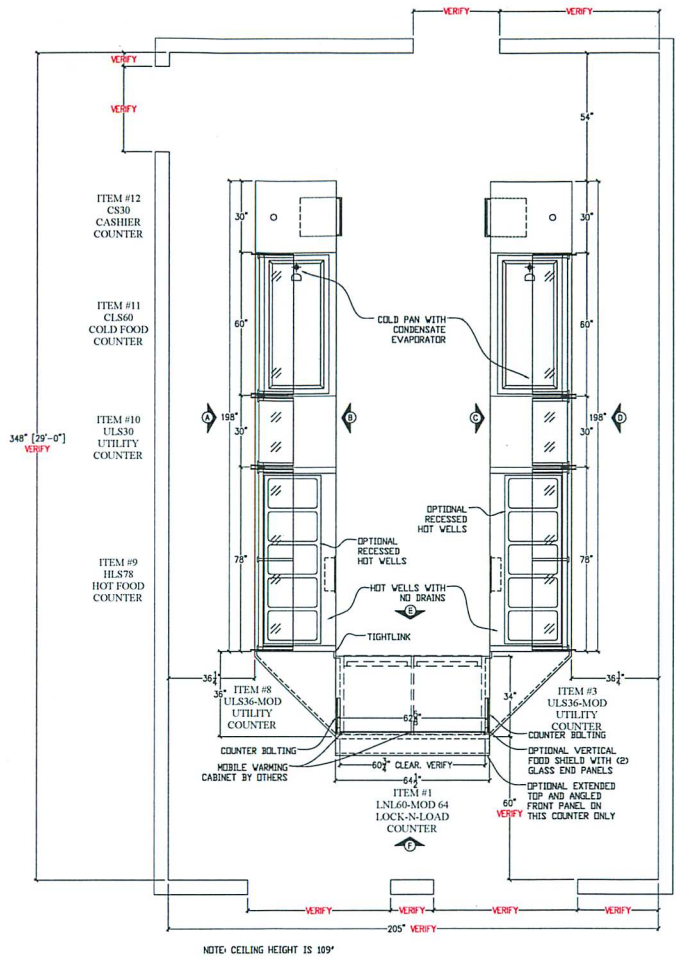

NOTE: CEILING HEIGHT IS 109'

- ITEM #7 CS30 CASHIER COUNTER
- ITEM #6 CLS60 COLD FOOD COUNTER
- ITEM #5 ULS30 UTILITY COUNTER
- ITEM #4 HLS78 HOT FOOD COUNTER

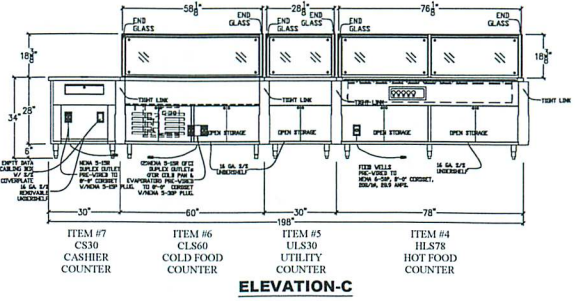

ELEVATION-C

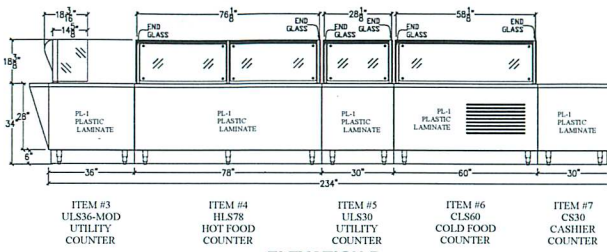

ELEVATION-D

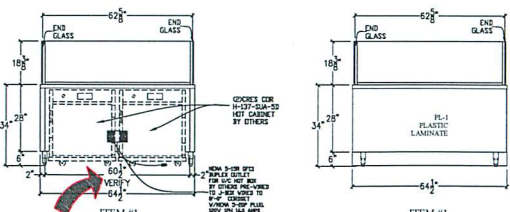

ELEVATION-E

ELEVATION-F

QTY	ITEM #	MANUFACTURER	MODEL NO.	DESCRIPTION	PO NOTES
2	4 & 9	HATCO	HWB1-S-CN	DROP-IN HOT FOOD WELL	MULTITERIA
2	8 & 11	HATCO	CWB-4	DROP-IN COLD FOOD WELL	MULTITERIA



- MATERIAL/COLOR SELECTIONS TO BE VERIFIED:**
- 1. COUNTERTOP: 14 GA. STAINLESS STEEL
 - 2. FOOD SHIELD: BLACK POWDER COAT FINISH OR STAINLESS STEEL FINISH
 - 3. TRAY SLIDE: N/A
 - 4. PL-1 LAMINATE: PLASTIC LAMINATE/MANUFACTURER MODEL
 - 5. KICK PLATE: BLACK POWDER COAT FINISH OR STAINLESS STEEL FINISH
- MANUFACTURING NOTES:**
- 1. 1" SQ. STAINLESS STEEL WELDED TUBULAR FRAMEWORK
 - 2. STANDARD ESSENCE CORNERS WITH REMOVABLE LAMINATE PANELS AND MOUNTING CHANNELS.
 - 3. 1-5/8" DIA. X 8" H STAINLESS STEEL LEGS WITH ADJUSTABLE BULLET FEET.
 - 4. OPTIONAL STAINLESS STEEL DOORS ON OPERATOR SIDE TO HAVE TWIST LATCH.
 - 5. NO DRAINS IN HOT WELLS.
 - 6. CONDENSATE EVAPORATOR IN COLD FOOD COUNTERS.

PRELIMINARY DRAWING NOT FOR CONSTRUCTION

SUBMITTAL DRAWING FOR APPROVAL

RESUBMITTAL DRAWING FOR APPROVAL

AS-BUILT DRAWING

KEC SIGNATURE

DATE

APPROVED AS DRAWN

APPROVED AS NOTED

REVISE AND RESUBMIT

REVISED
X
X
X
X
X

OAK PARK H.S.
X
OAK PARK, CA

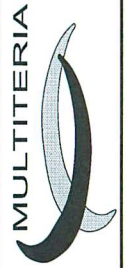

MULTITERIA
1444 N FARNSWORTH AVE
AURORA, IL 60505

SHEET NO.
2
of 3

PROJECT NO.
2380.09.02.15E

DATE: 10/14/15

SCALE: 1/2"=1'-0"

DRAWN BY: FOX
AUTOCAD D SIZE

REVISED

X
X
X
X
X

OAK PARK H.S.
X
OAK PARK, CA



MULTITERIA
1444 N FARNSWORTH AVE
AURORA, IL 60505

MULTITERIA RESERVES PROPRIETARY RIGHTS TO THIS DRAWING AND THE DATA HEREIN. THIS DRAWING MUST BE KEPT UNDER LOCK AND KEY AND NOT BE LOANED, REPRODUCED, COPIED, REPRODUCED, OR ANY OTHER MANNER WITHOUT WRITTEN CONSENT OF MULTITERIA.

SHEET NO.

1

OF 3

PROJECT NO.
2380.09.02.15E

DATE: 10/14/15

SCALE: 1/2"=1'-0"

DRAWN BY: FOX
AUTOCAD SIZE

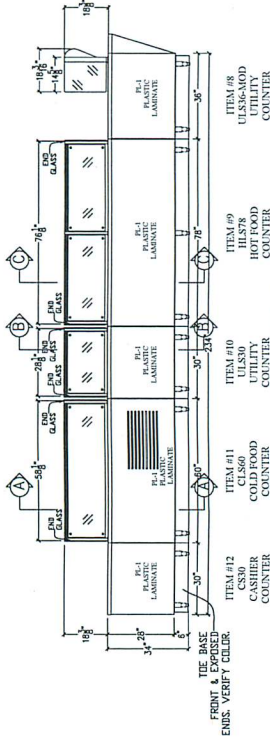

ELEVATION-A

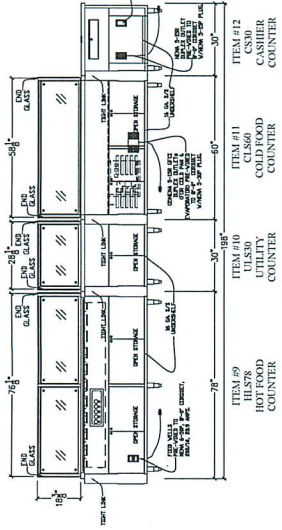

ELEVATION-B

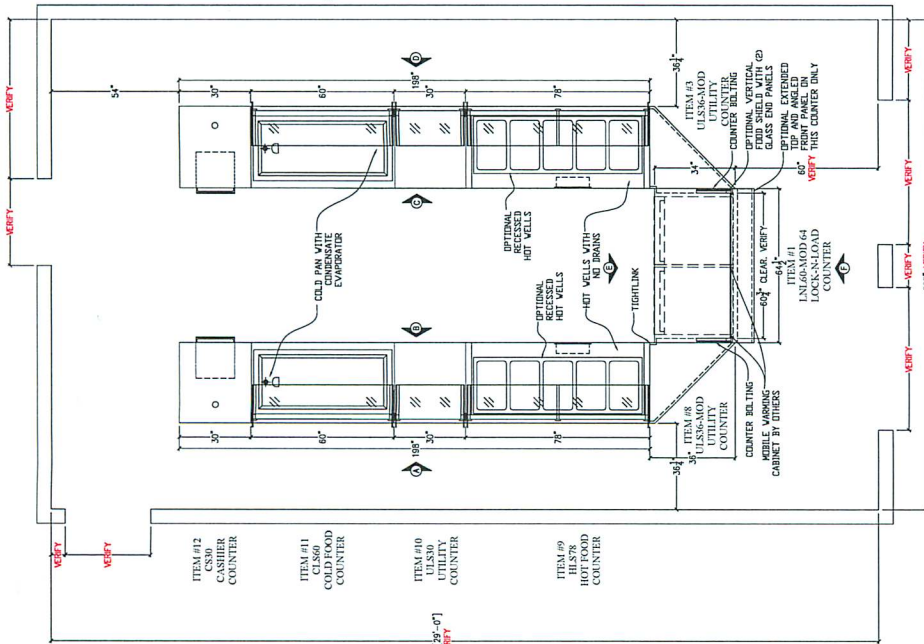

NOTE: CEILING HEIGHT IS 109'



QTY	ITEM #	MANUFACTURER	MODEL NO.	DESCRIPTION	PO NUMBER
2	449	HATCO	HMB-F-ON	PROP-IN HOT FOOD WELL	MULTITERIA
	811	HATCO	CHL-4	PROP-IN COLD FOOD WELL	MULTITERIA

PRELIMINARY DRAWING NOT FOR CONSTRUCTION
 SUBMITTAL DRAWING FOR APPROVAL
 RESUBMITTAL DRAWING FOR APPROVAL
 AS-BUILT DRAWING

KFC SIGNATURE _____ DATE _____
 APPROVED AS DRAWN _____
 APPROVED AS NOTED _____
 REVISE AND RESUBMIT _____

MATERIAL/COLOR SELECTIONS TO BE VERIFIED:
 1. 1" SO. STAINLESS STEEL, WELDED TUBULAR FRAMEWORK
 2. STANDARD ESSECE CORNERS WITH REMOVABLE LAMINATE PANELS AND MOUNTING CHANNELS
 3. TRAY SUBC. N/A
 4. OPTIONAL STAINLESS STEEL DOORS ON OPERATOR SIDE TO HAVE TRIST LATCH.
 5. COMPASS & WIPER IN COLD FOOD COUNTERS.
 6. STAINLESS STEEL DOORS ON OPERATOR SIDE WITH TRIST LATCHES.
 7. STAINLESS STEEL DOORS ON OPERATOR SIDE WITH TRIST LATCHES.

REVISED

X
X
X
X
X

OAK PARK H.S.
X
OAK PARK, CA



MULTITERIA
1444 N FARNSWORTH AVE
AURORA, IL 60505

MULTITERIA RESERVES PROPRIETARY RIGHTS TO THIS DRAWING AND THE DATA SHOWN. THIS DRAWING IS NOT TO BE REPRODUCED OR TRANSMITTED IN ANY FORM OR BY ANY MEANS, ELECTRONIC OR MECHANICAL, WITHOUT WRITTEN CONSENT OF MULTITERIA.

SHEET NO.

3

Of 3

PROJECT NO.

2380.09.02.15E

DATE: 10/14/15

SCALE: 1/2"=1'-0"

DRAWN BY: FOX

AUTOCAD D SIZE

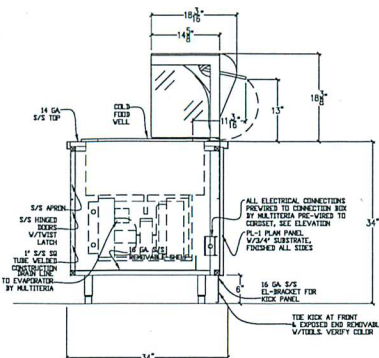

ITEM #11
CLS60
COLD FOOD
COUNTER
SECTION A

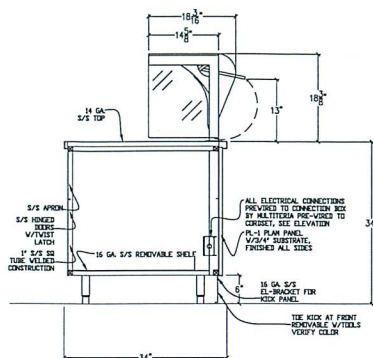

ITEM #10
ULS30
UTILITY
COUNTER
SECTION B

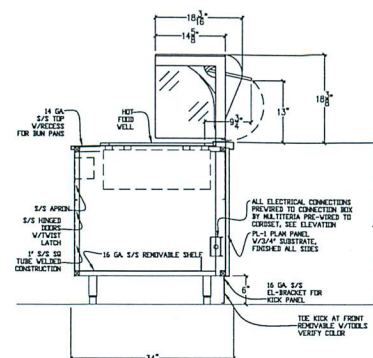

ITEM #9
HLS78
HOT FOOD
COUNTER
SECTION C

- MATERIAL/COLOR SELECTIONS TO BE VERIFIED:
- 1. COUNTERTOP: 14 GA. STAINLESS STEEL
 - 2. FOOD SHIELD: BLACK POWDER COAT FINISH OR STAINLESS STEEL FINISH
 - 3. TRAY SLIDE: N/A
 - 4. PL-1 LAMINATE: PLASTIC LAMINATE/MANUFACTURER/MODEL
 - 5. KICK PLATE: BLACK POWDER COAT FINISH OR STAINLESS STEEL FINISH

VERIFY
VERIFY
VERIFY

- MANUFACTURING NOTES:
- 1. 1" SQ. STAINLESS STEEL, WELDED TUBULAR FRAMEWORK
 - 2. STANDARD ESSENCE CORNERS WITH REMOVABLE LAMINATE PANELS AND MOUNTING CHANNELS.
 - 3. 1-5/8" DIA. X 6" H STAINLESS STEEL LEGS WITH ADJUSTABLE BULLET FEET.
 - 4. OPTIONAL STAINLESS STEEL DOORS ON OPERATOR SIDE TO HAVE TWIST LATCH.
 - 5. NO DRAINS IN HOT WELLS.
 - 6. CONDENSATE EVAPORATOR IN COLD FOOD COUNTERS.



PRELIMINARY DRAWING NOT FOR CONSTRUCTION
 SUBMITTAL DRAWING FOR APPROVAL
 RESUBMITTAL DRAWING FOR APPROVAL
 AS-BUILT DRAWING

KEC SIGNATURE _____ DATE _____

APPROVED AS DRAWN
 APPROVED AS NOTED
 REVISE AND RESUBMIT

TO: MEMBERS, BOARD OF EDUCATION

FROM: DR. ANTHONY W. KNIGHT, SUPERINTENDENT

DATE: OCTOBER 20, 2015

SUBJECT: B.2.j. APPROVE MEASURE C6 BOND FUND EQUIPMENT PURCHASES - DISTRICTWIDE SECURITY CAMERAS, PHASE 2 ACTION

ISSUE: Shall the Board approve a Measure C6 bond fund equipment purchase for Districtwide Security Cameras, Phase 2, and delegate limited authority to the Superintendent to award contracts for this project?

BACKGROUND: After the installation of the security camera system completed in 2014, it has been determined that additional cameras and related cabling are needed at each site to provide sufficient coverage of the respective campuses. A total of 25 cameras are required, at an estimated cost of \$80,000 for equipment and \$20,000 for cabling. Proposals have been requested from the vendors used in Phase 1 of this project, Blue Violet Networks for cameras, and Pacific Coast Sound and Communications (PacifiCom) for the cabling.

Proposals will be received shortly after this evening's Board meeting. Time is of the essence for this project, as award of contracts at the earliest possible time is required to ensure completion of the work during the upcoming winter break. Education Code (EC) Section 17604 permits the Board to delegate authority to award contracts to the Superintendent, provided that the Board ratifies the award at a future meeting. Staff is recommending implementation of EC 17604, delegating limited authority to the Superintendent to award contracts for this project as follows: 1) contracts will be awarded in strict conformance with all applicable law; 2) proposed contracts will be reviewed by the Superintendent and staff, considering price, quality, value and needs of the District, and determination of an award of contract, if any, shall be made by the Superintendent; and 3) any contract awarded shall be presented for Board approval at its regular meeting on November 17, 2015.

As approved by Oak Park voters, Bond Measure C6 (School Safety, Equipment, and Technology Improvement) specifically provides for the purchase of equipment and technology and "equipping school facilities...to improve student safety ...". It is recommended that this project be funded from the Measure C6 bond fund.

ALTERNATIVES:

1. Delegate limited authority to the Superintendent to award contracts for Districtwide Security Cameras, Phase 2, as specified above, to be funded from the Measure C6 bond fund.
2. Do not approve the equipment purchase.

BOARD MEETING, OCTOBER 20, 2015

Item B.2.J. Approve Measure C6 Bond Fund Equipment Purchase

Districtwide Security Cameras, Phase 2

Page 2

RECOMMENDATION: Alternative No. 1

Prepared by: Martin Klauss, Assistant Superintendent, Business and Administrative Services

Respectfully submitted,

Anthony W. Knight, Ed.D.
Superintendent

Board Action: On motion of _____, seconded by _____, the Board of Education:

VOTE	AYES	NOES	ABSTAIN	ABSENT
Hazelton	_____	_____	_____	_____
Helfstein	_____	_____	_____	_____
Laifman	_____	_____	_____	_____
Rosen	_____	_____	_____	_____
Ross	_____	_____	_____	_____
Student Rep	_____	_____	_____	_____